

ISO *Insert milling cutters*

*for the machining of
steel, cast and aluminium*

H
HOLLFELDER
GÜHRING
CUTTING TOOLS

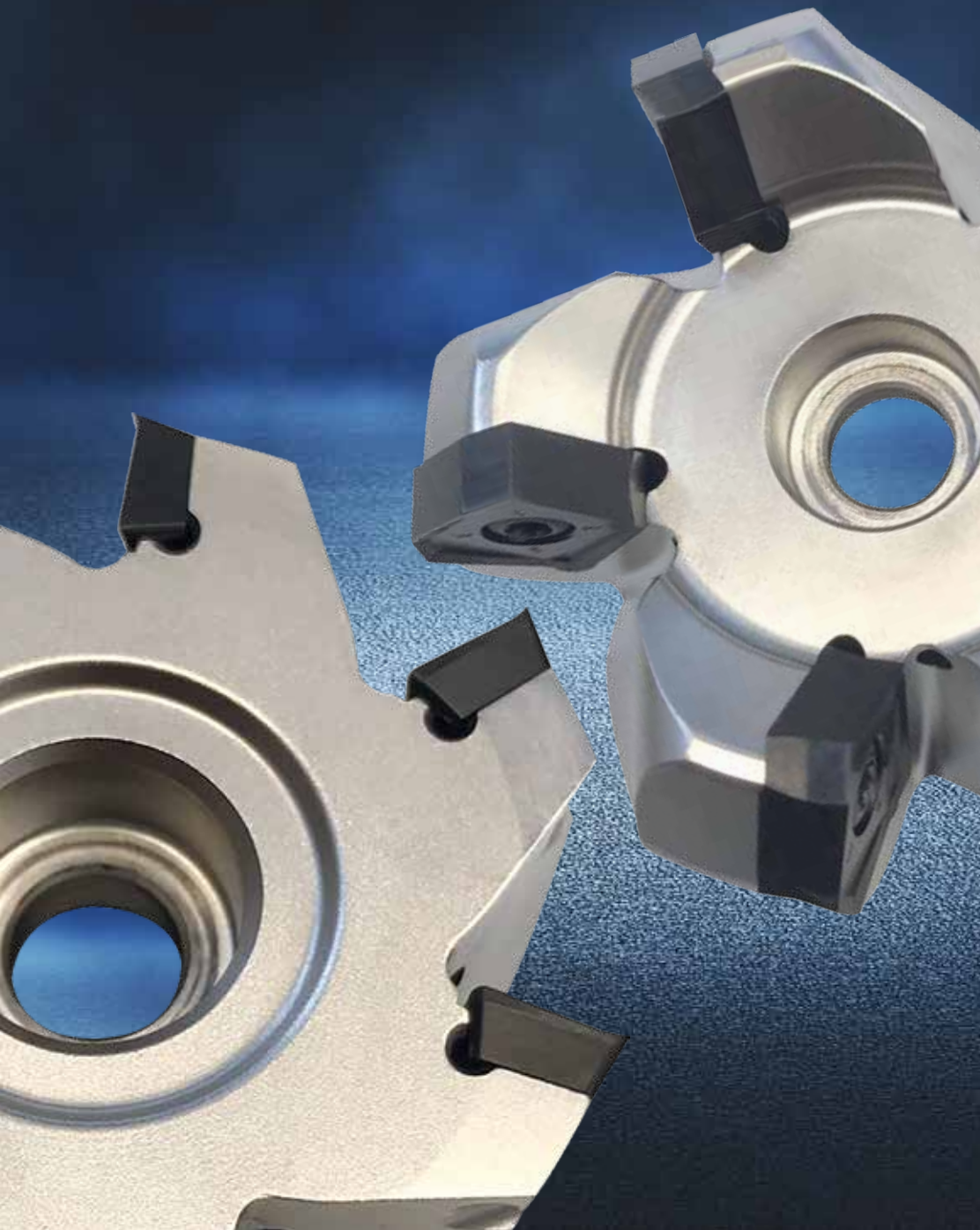

Face milling cutters

for the machining of
steel, cast and aluminium

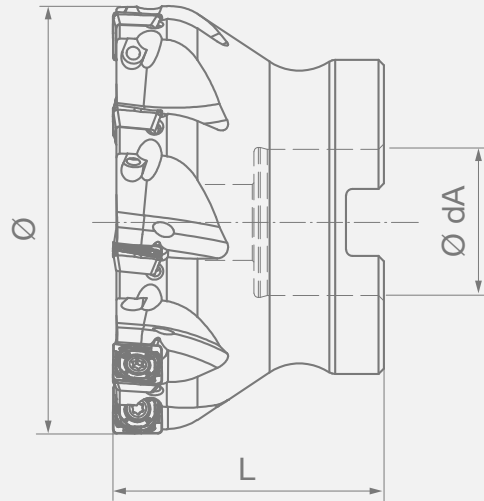

➤ Face milling cutters

Ø mm	Z	Ø dA	L mm	n max.	Drawing no.	Material no.
25	3	25*	88	23700	IH SDKT-2500 3225R	303599930
32	4	32*	100	19700	IH SDKT-3200 4032R	303599931
40	5	16	40	17000	IH SDKT-4000 4016R	303599932
50	6	22	40	14800	IH SDKT-5000 4022R	303599933
63	7	22	40	12850	IH SDKT-6300 4022R	303599934
80	9	27	50	11250	IH SDKT-8000 5027R	303599935

* mit Zylinderschaft DIN 1835 B

➤ Inserts

Grade code	Substrate	Coating	Drawing no.	Material no.
Z10	P30	CVD	IP SDKT 09T308R HP01 Z10	303599899
Z12	P35	PVD	IP SDKT 09T308R HP03 Z12	303599900
Z13	M35	PVD	IP SDKT 09T308R HP05 Z13	303599901
Z30	S35	CVD	IP SDKT 09T308R HP07 Z30	303599917
Z31	S35	CVD	IP SDKT 09T308R HP09 Z31	303599918
Z03	K15	CVD	IP SDKT 09T308R HP11 Z03	303599919
Z02	N15	-	IP SDHT 09T308R HP13 Z02	303599920

➤ Application recommendations

Material no.	Steel	Stainless steel	Cast iron	Non-ferrous metals	Difficult-to-machine	a_p max.	v_c [m/min]	f_z [mm/z]
303599899	▲	●	●			8	100-180	0.15-0.25
303599900	▲	●				8	100-180	0.15-0.25
303599901	●	▲				8	100-160	0.10-0.18
303599917		▲			(▲*)	8	100-160	0.10-0.18
303599918					▲	8	* 30-70	0.06-0.12
303599919			▲			8	140-280	0.12-0.20
303599920			●	▲		8	<2000	0.18-0.30

▲ = very good applicable ● = applicable

Angular milling cutters

for the machining of steel and cast

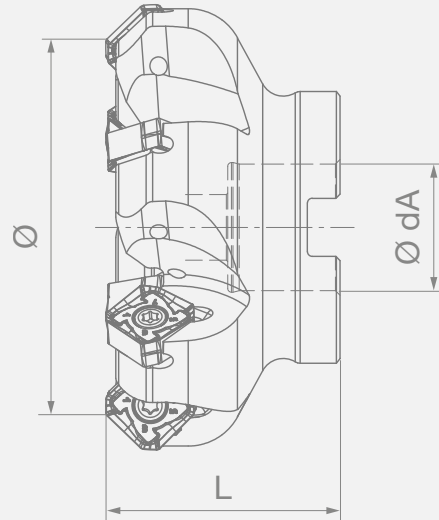

➤ Angular milling cutters

Ø mm	Z	Ø dA	L mm	n max.	Drawing no.	Material no.
40	4	16	45	19900	IH SOKU 4000 4516R	303599936
50	4	22	45	15900	IH SOKU 5000 4522R	303599937
63	5	22	45	12600	IH SOKU 6300 4522R	303599938
80	6	27	50	9900	IH SOKU 8000 5027R	303599939
100	7	32	50	7900	IH SOKU 1000 5032R	303599940
125	8	40	63	6300	IH SOKU 1250 6340R	303599941

➤ Inserts

Grade code	Substrate	Coating	Drawing no.	Material no.
Z10	P30	CVD	IP SOKU 1505 HP15 Z10	303599921
Z11	P35	CVD	IP SOKU 1505 HP17 Z11	303599923
Z12	P35	PVD	IP SOKU 1505 HP19 Z12	303599924
Z13	M35	PVD	IP SOKU 1505 HP21 Z13	303599925
Z30	S35	CVD	IP SOKU 1505 HP23 Z30	303599926
Z03	K15	CVD	IP SOKU 1505 HP25 Z03	303599927
Z04	K20	PVD	IP SOKU 1505 HP27 Z04	303599928

➤ Application recommendations

Material no.	Steel	Stainless steel	Cast Iron	Non-ferrous metals	Difficult-to-machine	a_p max.	v_c [m/min]	f_z [mm/z]
303599921	▲	●	●			6.5	100-180	0.15-0.40
303599923	▲	●				6.5	100-180	0.15-0.40
303599924	▲	●				6.5	100-180	0.15-0.40
303599925	●	▲				6.5	100-160	0.12-0.30
303599926		▲			(▲*)	6.5	100-160	0.12-0.30
303599927			▲			6.5	140-280	0.12-0.35
303599928			▲			6.5	140-280	0.12-0.35

▲ = very good applicable

● = applicable



HOLLFELDER
GÜHRING
CUTTING TOOLS

HOLLFELDER-GÜHRING CUTTING TOOLS

Wertachstrasse 27 • D - 90451 Nuremberg • Germany

Phone + 49 (0) 911 / 64 19 22-0 • Fax + 49 (0) 911 / 64 19 22-10

E-mail: info@hollfelder-guehring.de • Internet: www.hollfelder-guehring.de

Products, technical data and price subject to change.

19006-VIII-03 | Printed in Germany | 2019